

Branding Template

Design template for promotional advertising **CKC10/BK, „CAR KEY CASE PRO“**

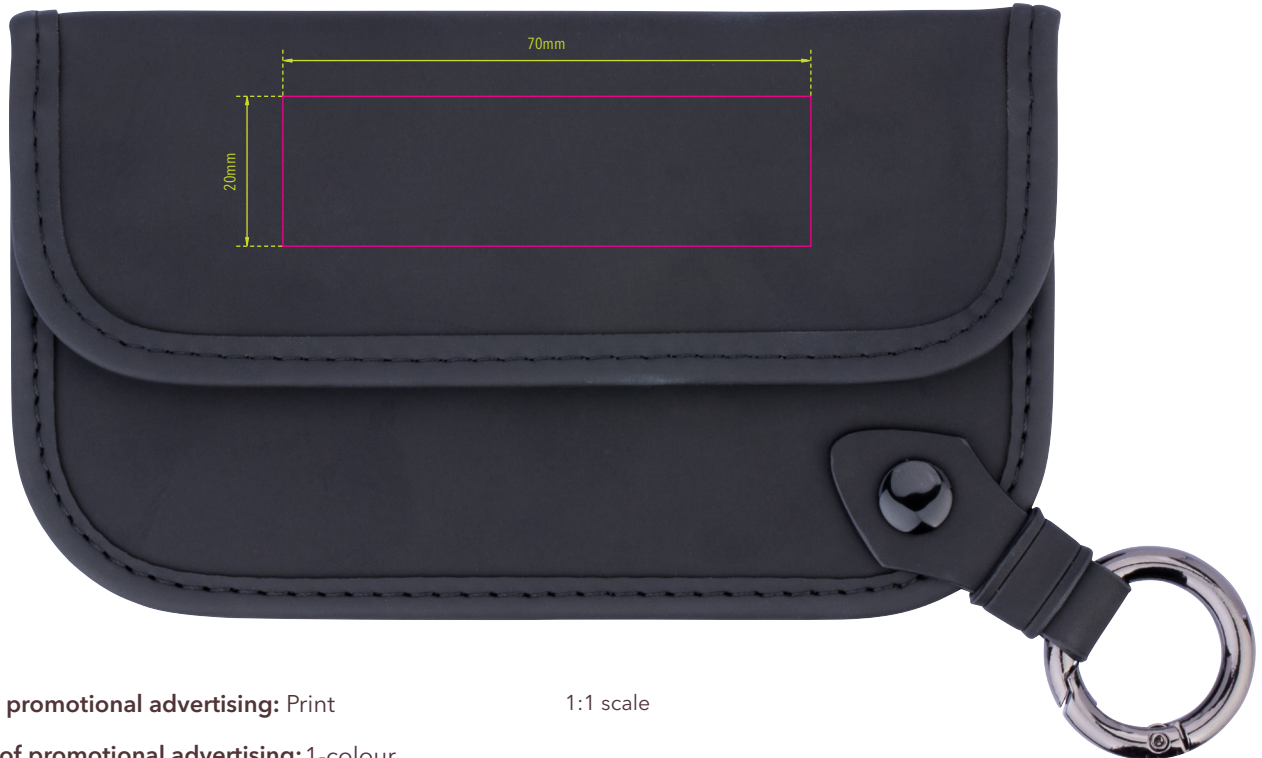

Type of promotional advertising: Print

1:1 scale

Colour of promotional advertising: 1-colour

Product dimensions: 140 x 80 x 12 mm

Dimensions of promotional advertising: 70 x 20 mm

Protective case with fraud protection for car keys and all other radio frequency keys with RFID and NFC chip, 2 interior compartments (key compartment fraud protected) incl. Velcro, carabiner, imitation leather, polyester, black

